



Dometic

INSTALLATION AND OPERATING INSTRUCTIONS

REFRIGERATOR FOR LP-GAS AND ELECTRIC OPERATION.

FOR YOUR SAFETY

If you smell gas:

1. Open windows.
2. Don't touch electrical switches.
3. Extinguish any open flame.
4. Immediately call your gas supplier.

	Page
Installation	5-8
Instructions for use	9-10
Gas equipment	10
Electric equipment	10-11
Maintenance	11
Fault tracing	11
Door panel	12

DISTRIBUTORS

EAST OF ROCKY MOUNTAINS

Dometic Sales Corporation
2320 Industrial Parkway
P O Box 490
Elkhart, Indiana 46515

WEST

DOMETIC SALES CORPORATION
14441 Bonelli Street
City of Industry, Calif 91746

CANADA

DOMETIC CANADA INC
P O Box 212
Oakville, Ontario L6J 5A2

REFRIGERATORS WITH
AUTOMATIC IGNITION

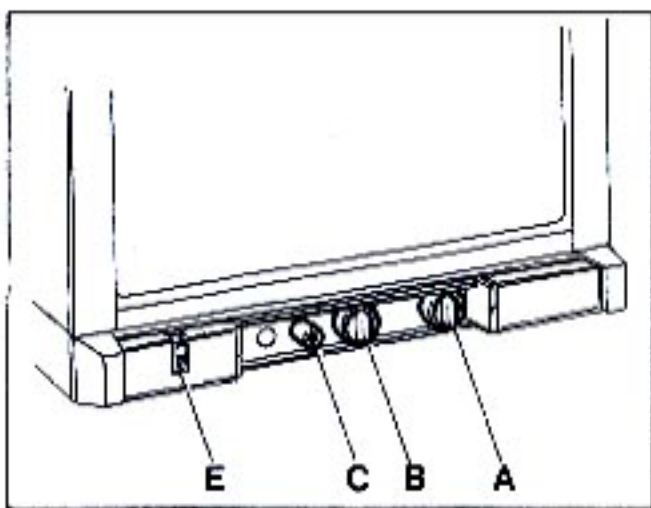
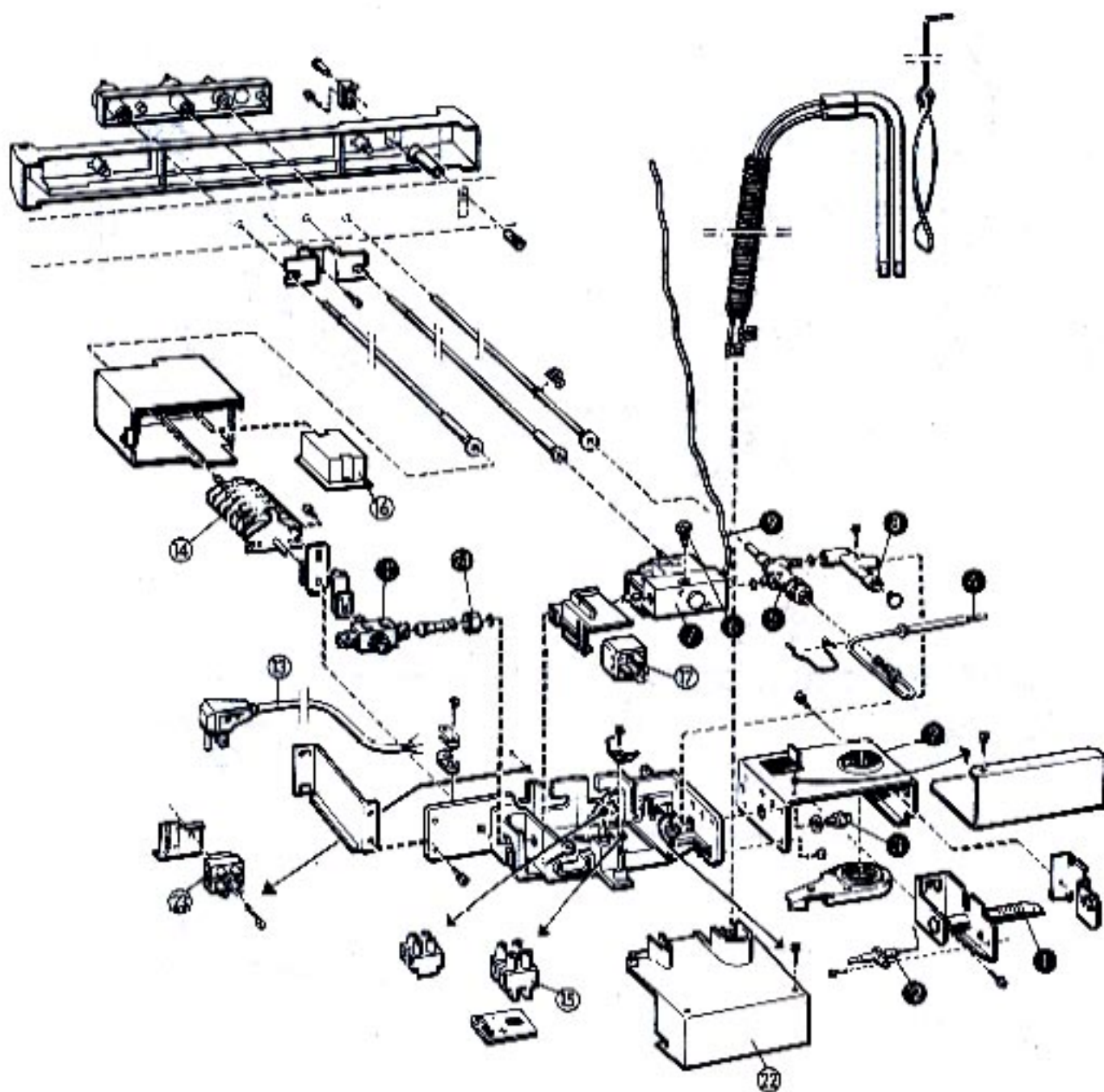

Fig. 4b.

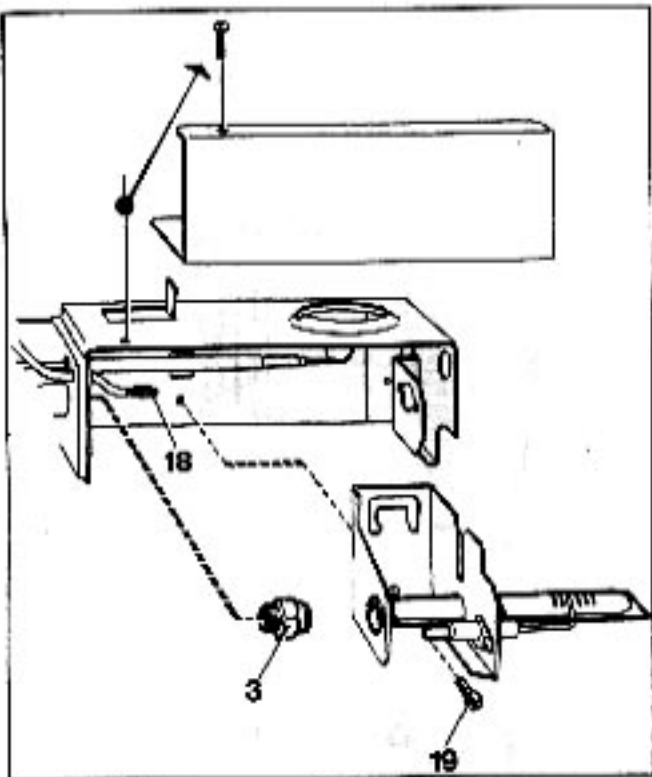

Fig. 2

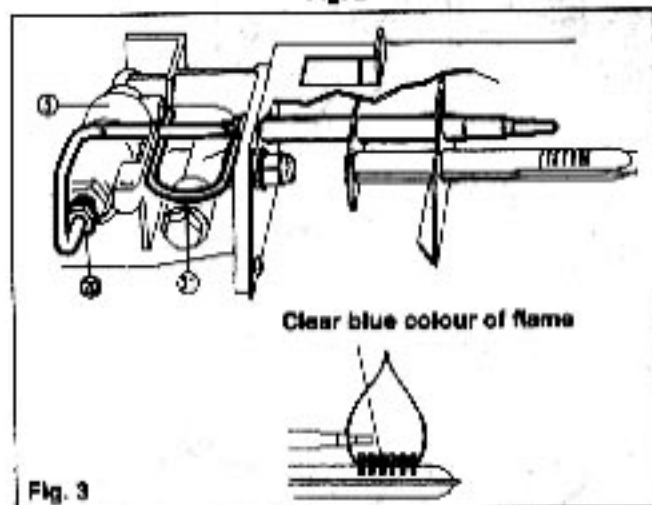

Fig. 3

Gas equipment parts

1. Burner tube
2. Burner housing
3. Burner jet
4. Feeler point (thermocouple)
5. Flame failure safety device
6. Bypass screw
7. Gas/Electric thermostat
8. Pressure test gage connection
9. Capillary tube for thermostat
10. Shut-off valve
11. Plazzo igniter (lighter)
12. Firing tip
24. Hexagon nut

Electric equipment parts

13. Flexible cord
14. Change-over switch
15. Terminal block, 12 V DC
16. Relgnter
17. Relay
22. Cover
23. Terminal block, 12 V DC, on certain models only

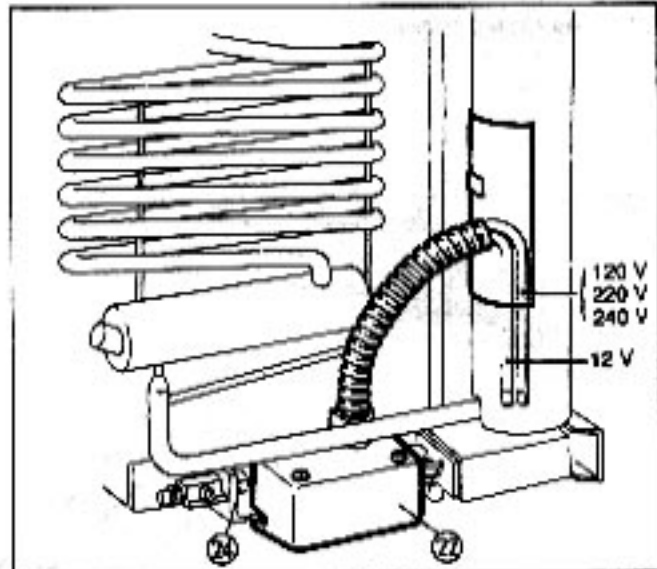

Fig. 5

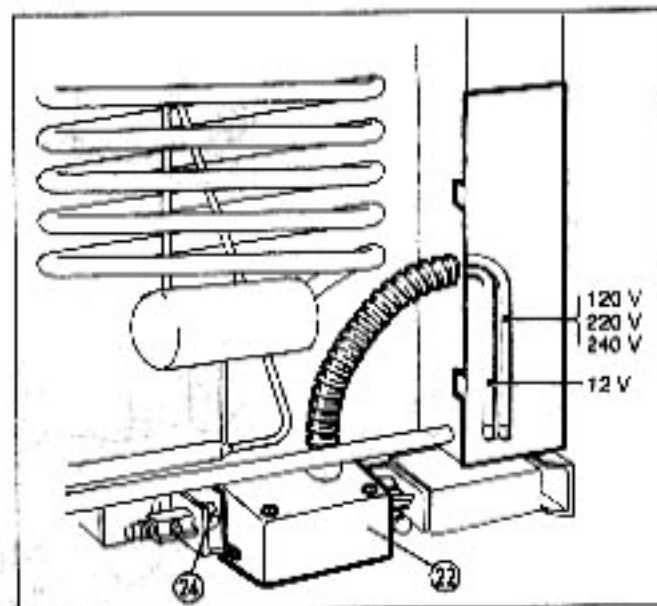

Fig. 6

INSTALLATION



GENERAL INSTRUCTIONS

The refrigerators outlined hereon have been design certified under ANS Z 21.19 Refrigerators by the American Gas Association for installation in a mobile home or recreational vehicle and are approved by the Canadian Gas Association.

The certifications are, however, contingent on the installation being made in accordance with the following instructions as applicable.

The installation must in the USA conform with:

1. National Fuel Gas Code Z223.1-1974
2. Mobile Homes A119.1-1975
3. Recreational Vehicles A119.2-1975

The unit must be electrically grounded in accordance with the National Electric Code ANSI, C1- 1976 when installed if an external alternating current electrical source is utilized.

4. Any applicable local code

In Canada

1. Standard CGA 10.1/CSA Z240.4. gas equipped mobile housing and recreational vehicles
2. Standard CSA Z240.6.1 electrical requirements for mobile housing
3. Standard CSA Z240.6.2/C22.2 No 148 electrical requirements for recreational vehicles.

Ventilation

The installation shall be made in such a manner as to separate the combustion system from the living space of the mobile home or recreational vehicle. Openings for air supply or for venting of combustion products shall have a minimum dimension of not less than 1/4 inch.

Proper installation requires one lower fresh air intake and one upper exhaust vent. The ventilation kits shown in this instruction booklet have been certified for use with the refrigerator models listed in the tables. Certified vent system kits, see separate list. The ventilation kits must be installed and used without modification. An opening towards the outside at floor level in the refrigerator compartment must be provided for ventilation of heavier-than-air fuel gases. The lower vent of the recommended kits is provided with proper size openings. The flow of combustion and ventilating air must not be obstructed.

For ready serviceability of the burner and control manifold parts of the refrigerator the lower side vent is fitted with a liftout panel which provides an adequate access opening.

GAS CONNECTION

Hook-up to the gas supply line is accomplished at the manual gas valve, which is furnished with a 3/8" SAE (UNF 5/8"- 18) male flare connection. All completed connections should be checked for leaks with soapy water.

The gas supply system must incorporate a pressure regulator to maintain a supply pressure of not more than 11 inches water gage.

In case detailed instructions on the installation and connection to the gas supply are required, contact your dealer or distributor.

ELECTRICAL CONNECTION

120 Volts A C

The refrigerator is equipped with a three prong (grounded) plug for protection against shock hazards and should be plug-

ged directly into a properly grounded three prong receptacle. Do not cut or remove the grounding prong from this plug. The cord should be routed to avoid coming in contact with the burner cover, flue cover or other hot components.

Refrigerator models requiring 12 V DC supply

On units provided with interior light or automatic reigniter or both there is one additional terminal block marked "12 V". On "Tri-Power" units with interior light or automatic reigniter or both there are two additional blocks.

The refrigerator must be connected to the battery circuit with two wires of adequate capacity to avoid voltage drop. The wire gage should be chosen with consideration to the wire length in accordance with table below. The 12 V circuit must be fused. Maximum circuit fuse size: 15 Amps. for the models RM 360 and RM 460, 20 Amps. for RM 660, 30 Amps. for RM 760 and RM 1300.

Do not use the body or chassis of the vehicle as a substitute for either of the two conductors. No other electrical equipment or lighting should be connected to the refrigerator circuit. The refrigerator will draw from 10 to 23 Amps at 12 Volt depending on model.

The interior light and the reigniter must be connected to a separate battery circuit and will draw about 1 Amp.

Maximum two conductor wire length in feet

AWG	RM360 125W	RM460 135W	RM660 175W	RM760 250W	RM1300 275W	Interior light only 10W
14	10	9	7	6	4	17
12	17	15	12	8	7	36
10	27	25	19	13	12	56
8	43	40	31	22	19	86
6	69	64	49	34	31	136
4	110	102	79	55	60	220

CAUTION

Do not operate the refrigerator on 12 Volt when the vehicle is parked. You will run out of battery in a rather short time.

It possible the installation of a 12 Volt operated refrigerator should be completed with a relay mounted either in the car or in the recreational vehicle (see Fig below). This relay will automatically cut out the refrigerator when the car motor is stopped.

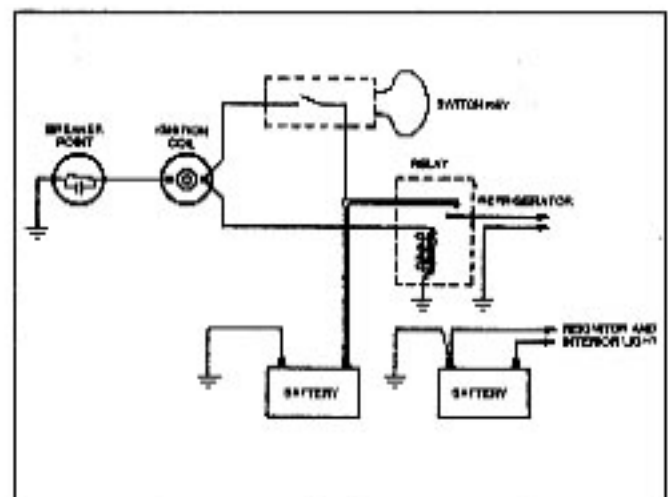

Fig. 7

SPECIAL HINTS

The refrigerator must be installed in a substantial enclosure and must be level. A spirit level is supplied with each refrigerator and by placing it in the freezer compartment one can level the refrigerator both ways front to back and side to side. When installing the refrigerator in the enclosure care should be taken to ensure a complete sealing between the front frame of the refrigerator and the top, sides and bottom of the enclosure. For this purpose a length of sealing strip is applied to the rear surfaces of the front frame. A sealing strip should also be applied to the foremost floor of the enclosure as shown in fig 8. The sealing should provide a complete isolation of the appliance combustion system from the vehicle interior.

Be careful not to damage the sealing strip applied to the floor of the enclosure when the refrigerator is put in place.

In the front frame and in the base at the rear of the refrigerator there are holes for screws for fixing the refrigerator in the enclosure. (Fig. 13).

Any space between counter or storage area and the top of the refrigerator must be blocked. The heat produced at the rear of the refrigerator will otherwise become trapped in this space making the top of the refrigerator hot and reducing the efficiency of the refrigerator.

Do not install so that an adjacent heat producing appliance will affect the construction or performance of the refrigerator.

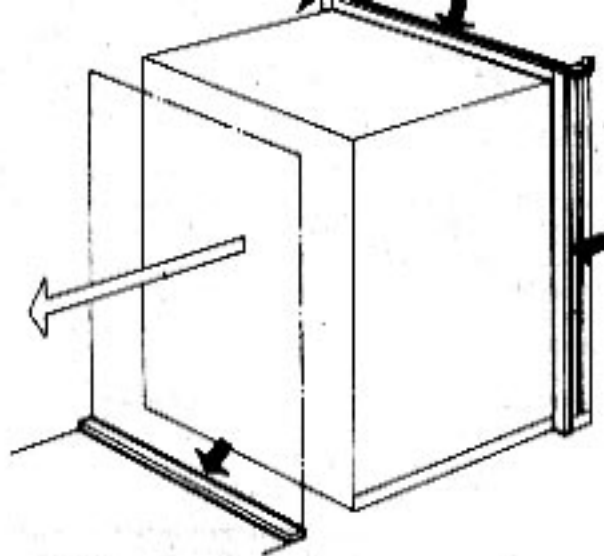

Fig. 8

TO CHANGE THE DOOR OPENING FROM LEFT TO RIGHT OR VICE VERSA

Open the door and unscrew the two screws holding the top front cover. The screws are accessible from beneath. Remove the top hinge pin and lift out the door.

The lower pin for the refrigerator door should be shifted to the opposite side.

The door can then be remounted. Before the top front cover is refitted check that the door closes easily and that the gasket seals well on all sides.

TO REMOVE AND REPLACE THE REFRIGERATOR

Before working on the refrigerator make sure that 120 V A.C. and optional 12 V D.C. leads are disconnected.

Unscrew the hexagon nut 24 and move the valve on the gas line out of the bracket. Check that the valve slips out of the dip connection with the switch shaft.

Loosen the screws fixing the refrigerator to the enclosure and remove the refrigerator.

When replacing the refrigerator make sure that the sealing strips are properly positioned. After reassembly the gas connection should be checked for leaks.

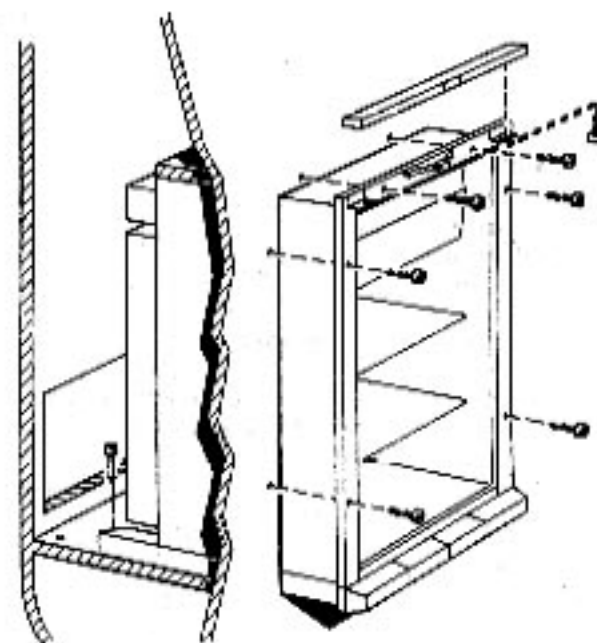

Fig. 13

CERTIFIED INSTALLATION

Certified installations require one roof vent and one lower side vent or as optional one upper vent and one lower side vent. The two alternatives are provided for by using the different kits listed in the Appendix. For further information contact your dealer or distributor.

METHODS OF INSTALLATION

The methods of installation are shown in figures 9 and 10. It is essential that all maximum or minimum dimensions are strictly maintained as the performance of the refrigerator is dependent on an adequate flow of air over the rear of the refrigerator.

VENTILATION HEIGHTS

Refrigerator	Minimum ventilation heights in inches	
	Installation with upper and lower side vent	Installation with roof vent and lower side vent
RM360	37	31
RM460	—	34
RM660	—	42
RM760	—	56
RM1300	—	62

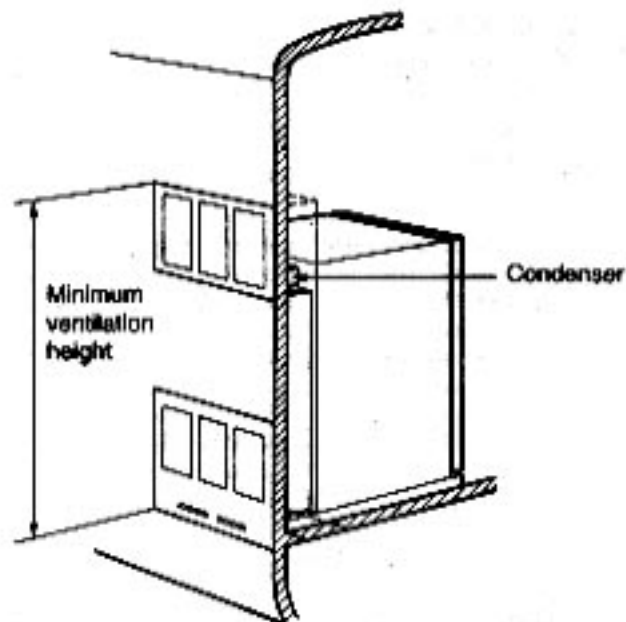

Fig. 9

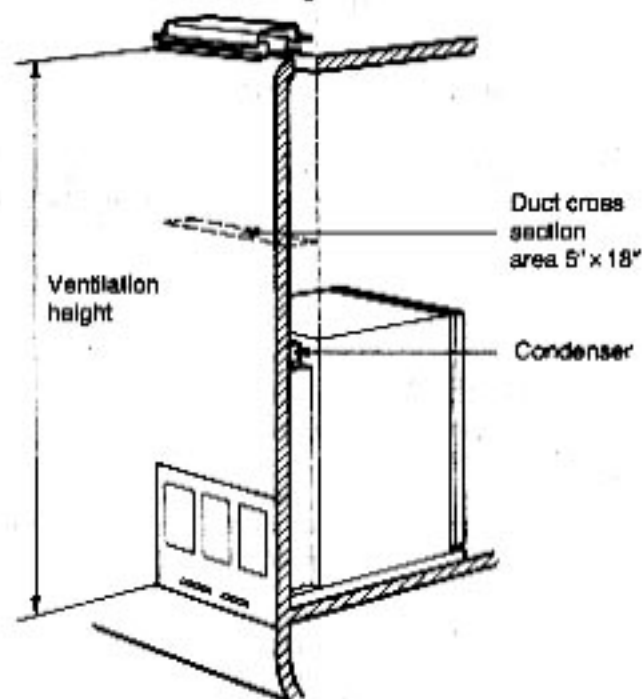

Fig. 10

CLEARANCES

Minimum clearances in inches to combustible materials are

- G: Top 0
K: Side 0
L: Bottom 0
M: Rear 1

Clearance M between the rear-most part of the refrigerator and the wall behind the refrigerator

Clearance N on top of the condenser is related to the minimum ventilation height

See Fig 11 and examples below

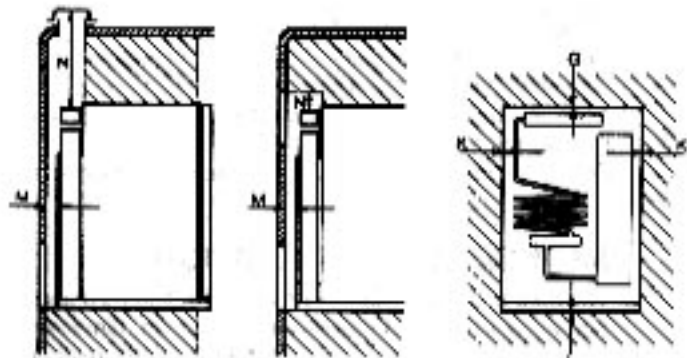

Fig. 11

Refrigerator model	Overall dimensions			Installation dimensions			Recess dimensions			Distance between top of condenser to top of refrigerator e
	Height A	Width B	Depth C	Height h	Width w	Depth d	Height H	Width W	Depth D	
RM 360	30 3/8	21 11/16	22 1/16	29 9/16	20 1/4	20 3/16	29 3/4	20 1/2	21 3/16	1 1/4
RM 480	32 15/16	23	24 11/16	32 1/8	21 9/16	22 3/4	32 5/16	21 13/16	23 3/4	1 1/4
RM 680	40 13/16	23	24 11/16	40	21 9/16	22 3/4	40 3/16	21 13/16	23 3/4	1 1/4
RM 760	52	23	24 11/16	51 3/16	21 9/16	22 3/4	51 3/8	21 13/16	23 3/4	1/8
RM 1300	57 15/16	24 15/16	24 11/16	57 1/8	23 7/16	22 3/4	57 1/2	23 13/16	23 3/4	1/8

EXAMPLES

The clearance N for the RM360 model is derived as in the following way

A Installation with upper and lower side vents

N = Minimum ventilation height 37 minus installation height 29 9/16 plus distance between condenser top and refrigerator top 1 1/4

$$N = 37 - 29 \frac{9}{16} + 1 \frac{1}{4} = 8 \frac{11}{16}$$

B Installation with roof vent and lower side vent

N = Minimum ventilation height 31 minus installation height 29 9/16 plus distance between condenser top and refrigerator top 1 1/4 plus distance between roof surface and roof vent cap 5 1/4

$$N = 31 - 29 \frac{9}{16} + 1 \frac{1}{4} + 5 \frac{1}{4} = 7 \frac{15}{16}$$

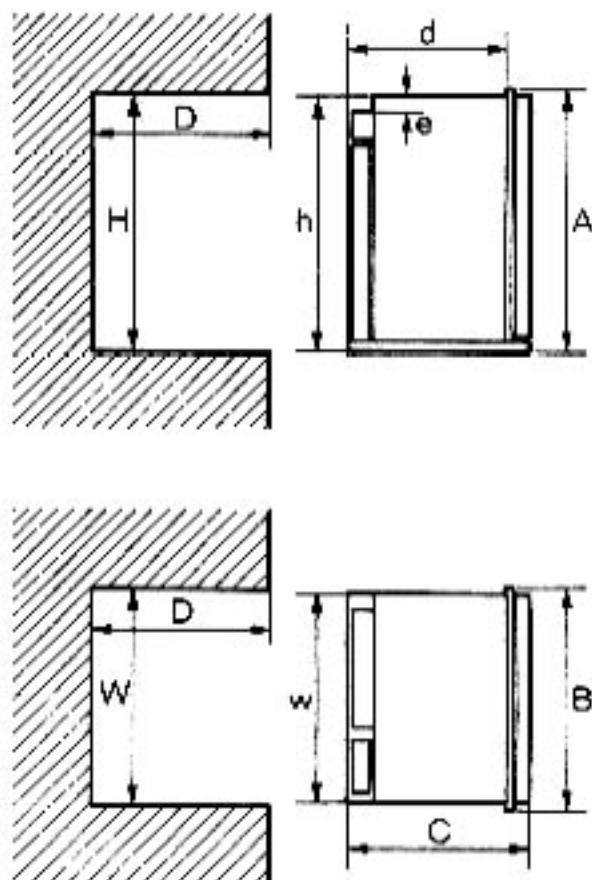

Fig. 12

INSTRUCTIONS FOR USE

HOW TO START THE REFRIGERATOR

Leveling

In the boiler ammonia vapor is distilled from an ammonia-water mixture and carried to the finned condenser, where it liquefies. The liquid flows to the evaporator, where it creates cold by evaporating into a circulating flow of hydrogen gas. If the evaporator coil is not level the liquid readily accumulates, forming pockets which can impair the gas circulation or even block it, in which case, of course, the cooling will stop.

When the recreational vehicle is stationary it must be leveled to be comfortable to live in. If the refrigerator is properly installed, the freezer shelf parallel to the floor, the refrigerator will then also perform well.

A bubble level should be placed on the freezer shelf. When the vehicle is on tow, the continuous rolling and pitching movement will not affect the refrigerator as long as the movement passes either side of level, but when the trailer is temporarily parked this sensitivity of the refrigerator should be remembered. So, once more, before you start the refrigerator make sure it is level.

Gas Operation (Fig. 4a) with piezo igniter

1. To start the refrigerator turn the knob A to position "GAS"
2. Turn the thermostat knob B to setting 4
3. Push the button C to stop and push the button D of the piezo igniter. The pushing has to be repeated until the gas is lit at the burner. This can be observed through the reflector E
4. After the gas is lit keep the button C pushed for 10 seconds. Release the button and check through the reflector that the burner flame stays burning. If not repeat the lighting procedure.

To shut off the refrigerator turn the knob A to off position.

NOTE: As soon as the necessary cold temperature inside the cabinet has been reached, adjust the thermostat knob to required setting.

Gas operation (Fig. 4b) with automatic reigniter

1. To start the refrigerator turn the knob A to position gas. Lamp E comes on.
 2. Turn the gas thermostat knob B to setting 4.
 3. Press the button C to stop and keep it depressed. When lamp E goes out wait 15 sec. and release button C. If the lamp comes on again, repeat the procedure. If flame blow out reignition will take place automatically.
- To shut off the refrigerator turn the knob A to off position.

NOTE: After a replacement of the gas container or a long shut off period the gas line is likely to be filled with air. In such a case the lighting procedure has to be repeated until the air is pushed out of the line and the gas has reached the burner.

Flame Blow Out

If trouble is encountered with the flame blowing out under specially windy conditions, try to avoid the wind blowing against the wall where vent outlets are located. If the trouble persists, set the thermostat to MAX. This later measure can of course only be temporary such as when the vehicle is on tow, for after a day or so at this setting the foodstuffs in the cabinet will freeze.

Electric Operation (Fig. 4)

1. Check that the attachment plug is correctly connected to the mains supply. When the refrigerator is equipped also for 12 Volts D C operation the low voltage connection is made at the marked terminals at the rear of the refrigerator
 2. Turn the knob A to desired position for electric operation
 3. Turn the thermostat knob B to setting 4
- To shut off the refrigerator turn the knob A to off position.

HOW TO USE THE REFRIGERATOR

Food Storage Compartment

The food storage compartment is completely closed and unventilated, which is necessary to maintain the required low temperature for food storage. Consequently foods having a strong odor or liable to absorb odors should be covered. Vegetables, salads etc should be covered to retain their crispness. The coldest positions in the refrigerator are underneath the cooling evaporator and at the bottom of the refrigerator, and the least cold positions are on the upper door shelves. This should be considered when different types of food are placed in the refrigerator.

Defrosting

Some refrigerator models are equipped with an automatic defrosting device incorporated with the cooling unit. This device makes a quick defrost of the finned evaporator section about once a day without affecting the frozen food storage compartment or the frozen foods contained in it. When the frozen food storage compartment is covered with frost the refrigerator must be shut down temporarily till the frost is melted. Before the refrigerator is restarted the compartment should be dried, the ice trays washed and refilled with fresh water.

When the frost on the finned evaporator section has melted water will be collected in the drip tray. The drip tray should be emptied at regular intervals.

Some refrigerators without the automatic defrosting device should be defrosted regularly by turning off the refrigerator.

Empty the refrigerator leaving the drip tray under the finned evaporator and the cabinet and freezer doors open. If desired, defrosting may be speeded up by filling the ice tray with hot water and placing it in the freezer.

When all frost is melted, empty the drip tray and dry the interior of the refrigerator with a clean cloth.

Replace the drip tray and ice tray, replace all food stuffs and set the thermostat to MAX for a few hours. Then reset the thermostat knob to its normal position.

Frozen Food Storage Compartment

The ice trays should be placed in direct contact with the freezer shelf for fastest ice making. Quick frozen soft fruits and ice cream should be placed in the coldest part of the compartment which is at the bottom of the aluminum liner or, in models with a shelf, on this or just below it. Frozen vegetables, on the other hand, may be stored in any part of the compartment.

The compartment is not designed for the deep or quick freezing of foodstuffs. Meat or fish foods, whether raw or prepared, and provided they are precooled in the refrigerator, can however, also be stored in the frozen food storage compartment. They can then be stored about three times as long as in the fresh food storage compartment. To prevent drying out, keep food in covered dishes, in plastic bags or wrapped in aluminum foil.

Ice Making

Ice cubes can be made in the ice trays which should be filled with water to within 1/4" (5 mm) from the top. To release the ice cubes seize the tray with both hands and twist the tray as shown in fig O. Cubes not required should preferably be replaced in the tray. Refill the tray with water and replace the tray on the freezer shelf.

Ice making is accelerated if the thermostat knob is turned to setting "MAX". It is a good idea to do this a few hours before an anticipated need for ice but be sure to turn the knob back to normal setting when the ice is formed or the foodstuffs in the cabinet may become frozen hard.

To Shut Off the Refrigerator

To shut off the refrigerator turn the knob A to off position. If the cabinet is not in operation over a period of weeks, it should be emptied and cleaned and the door left ajar. Some models are provided with interior light, which comes on when the door is opened. To avoid running out of battery the light should be shut off with the knob underneath the lamp housing. The ice trays should also be dried and kept outside the cabinet.

Cleaning

To clean the interior lining of the refrigerator use lukewarm weak soda solution. The evaporator, ice trays and shelves must, however, be cleaned with warm water only. Never use strong chemicals or abrasives to clean these parts or the protective surface will be spoiled. It is important always to keep the refrigerator clean.

CAUTION

Do not store explosive substances in the refrigerator, such as cigarette lighter gas, petrol, ether or the like.

GAS EQUIPMENT

Flue Top and Baffle

The flue baffle is suspended from the top and must be in position in the central tube of the cooling unit.

The Burner and the Burner Jet (Fig. 2)

The slots of the burner must be centrally located under the boiler tube.

See "Periodic maintenance".

The Flame Failure Safety Device (Fig. 3)

The feeler of the thermo couple shall reach in over two slots of the burner. To replace the thermo couple proceed as follows:

1. Remove the plastic cover 22 (Fig. 5).
2. Unscrew plug 20 and pull thermo-couple straight out.
3. Remove spring 21.
4. Pull out thermo-couple sideways from burner housing.
5. Bend the new thermo-couple to the same shape as the old one.
6. Reassemble in reverse order. Check that feeler has been correctly refitted in relation to burner. See Fig. 3.
7. Mount plug 20, taking care not to damage the threaded hole in the aluminum cap of the housing. The plug must be properly tightened to the valve housing to ensure good contact between the thermo-couple and the magnetic coil within the housing.

The Thermostat

The refrigerator is equipped with a thermostat which is regulated by turning the knob to different settings in order to obtain the desired controlled cabinet temperature.

At OFF Under normal operating conditions the thermostat valve remains closed and the burner is running continuously at the by-pass rate, just enough to keep the burner lit.

At MAX The thermostat valve remains open and the burner is running continuously at full gas rate. Lowest cabinet and freezer temperatures are obtained at this setting.

Between these two extremas is a numbered portion of the dial over which various controlled temperatures can be obtained, the higher the number, the lower the temperature. As soon as the required cold temperature inside the cabinet is reached, the thermostat cuts the burner main flame leaving the by-pass flame to keep the safety valve open.

The Igniter

The refrigerator is fitted either with a piezo igniter (see fig. 4a) or an automatic reigniter (see fig. 4b), which does not normally need any maintenance. If the igniter does not work properly contact an authorized service point.

ELECTRIC EQUIPMENT

Cartridge heater

The refrigerator is equipped also for electric operation. Most models are equipped for both 120 Volts A C and 12 Volts D C operation.

The heat necessary for the operation of an absorption type cooling unit is supplied by an electric cartridge heater mounted in a pocket of the boiler system.

To replace the heater first of course check that the wall plug is disconnected. If the refrigerator is equipped also for 12 Volts D C operation make sure that the 12 V leads are disconnected. Then proceed as follows:

1. Remove the plastic cover (22) of the main control structure by loosening the two screws
2. Disconnect the heater leads
3. Pull off the metal hose

4. With a pair of pliers unfold the lug holding the lid of the boiler casing and open the lid
5. Remove some insulation wool so that the heater is accessible.
6. Turn and lift the heater out of its pocket
7. Fit the new heater into the pocket and pull on the hose around the leads
8. Connect the leads and put on the plastic cover
9. Re-seat the insulation and close the lid of the boiler casing

The Switch

The electric control also comprises an on-off switch operated by the selector knob at the front panel. The switch has two "on"-positions, one for 120 Volts A.C. (ELEC.) and one for 12 Volts D.C. operation.

The Thermostat

The electric thermostat is combined with the gas thermostat and is thus operated by the knob B at the front panel. The temperature in the refrigerator can be regulated by turning the thermostat knob to higher or lower numbers. Although the exact setting is not critical choose a setting at which the frost which gradually forms on the cooling evaporator is just maintained in dry condition.

It will be necessary to set the thermostat knob one or two numbers higher when the ambient temperature becomes higher or the load unusually heavy.

If less cooling is required a lower setting should be chosen.

PERIODIC MAINTENANCE

NOTE. Before working on the refrigerator make sure that 120 V A.C. and optional 12 V D.C. leads are disconnected.

The Burner and the Burner Jet (Fig. 2)

The colour of the flame shall be clear blue over the slots of the burner (Fig. 3).

Once or twice a year depending on use, it is necessary to clean and adjust the burner assembly. Proceed as follows:

1. Loosen screw and remove cover plate for burner housing.
2. Disconnect lighter cable from the electrode.
3. Loosen burner fixing cable and withdraw burner.
4. Clean burner tube with a brush. Blow with compressed air.
5. Screw off jet and clean with alcohol. Blow with compressed air. Never use a needle or similar.
6. Reassemble.

The Electrode

For a proper ignition function it is necessary to keep the electrode insulation dry and free from dirt. The gap between burner tube and electrode shall be max. $\frac{3}{16}$ " (5 mm) and min. $\frac{1}{4}$ " (3 mm).

WARNING

If the refrigerator is used intermittently it should be checked at least once a year.

It is important to keep the appliance area clear and free from combustible materials, gasoline and other flammable vapors and liquids. Check the venting system. The flow of combustion and ventilating air must not be obstructed. Check the flue baffle that it is clean and reasonably free from soot. Heavy soot formation indicates improper functioning of the burner. Clean baffle and flue. Further, clean cooling unit and floor under refrigerator.

The entire gas installation should be checked for leaks at intervals. Test all pipe connections with soapy water, not with an open flame.

NOTE. Any service of the gas controls, with exception for the above mentioned replacement, maintenance and cleaning operations must be performed by an authorized service center only.

FAULTTRACING

The refrigerator does not freeze satisfactorily

Causes and remedies

- a) Jet orifice clogged. Unscrew jet and blow clear or wash in alcohol. Do not use wire or pin to clean orifice.
- b) Check the leveling of the refrigerator.
- c) Flame has gone out. Remedy: 1) Gas in bottle is used up – refill. 2) Feeler point of the flame failure safety device is not heated enough by flame – check against fig. 2 or 3. 3) Clogged by-pass screw – clean or exchange it.
- d) Air circulation around cooling unit is restricted. Be sure that refrigerator is properly ventilated.
- e) The evaporator is heavily coated with frost. Defrost.
- f) Flue baffle not inserted into the central tube of the cooling unit.
- g) The thermostat is incorrectly used. See paragraph on thermostat. In hot weather the setting should be one or two numbers "colder" than usual.
- h) Gauze in burner head clogged. Clean.
- i) Burner damaged. Replace.
- j) Burner may be dislocated. Relocate.
- k) Wrong gas pressure at the burner. Have pressure checked at burner and at gas bottle. Pressure at burner must not fall below 11 " W.G. when thermostat is set on MAX.

ODOR FROM FUMES

Causes and remedies

- a. The flame touches side of the boiler due to dislocation of the burner. Relocate. Burner dislocation may also cause smoke and discoloring of walls and ceiling.
- b. Burner damaged. Replace.
- c. The flame touches flue baffle. Remedy: 1) Burner damaged. Replace. 2) Flue baffle too low. Correct the position of the baffle.
- d. The flue tube is dirty. Clean flue as follows: Cover burner and jet. Remove flue top and baffle. Clean flue with special flue brush. Clean baffle before putting back in place.

All the above instructions are to be followed closely. The refrigerator is quality-guaranteed. However, we are not responsible for any failures caused by improper adjustments and unfavorable installation conditions. Contact service point or distributor service dept. for assistance.

Replacement Parts Suppliers: See cover.

INSTRUCTIONS FOR MOUNTING THE DOOR PANEL

The refrigerator is normally delivered without door panel(s). Before starting the mounting work check that the panel dimensions are in compliance with those given in the table and read the instructions through. When mounting the panel, proceed as follows.

- Remove the top decoration strip (2) with its two screws (1).
- Insert one of the vertical edges of the panel into the groove of the door frame (3).
- Bend the panel gently so that the free side of the panel can be slipped into the corresponding groove of the door frame (4).
- Push the panel downwards so that the lower horizontal edge of the panel is fitted into the bottom groove (5).
- Between the upper edge of the panel and the door frame there is now a gap which should be covered by the decoration strip.
- Put the strip across the door so that the gap is covered and push it upwards (6). The tabs on the inside of the strip should fit in behind the flange of the door frame. Secure the decoration strip by means of the two screws (1).

Panel dimensions Thickness max. 5/32"

TYPE	HEIGHT		WIDTH		
	MAX.	MIN.	MAX.	MIN.	
RM 360	638 25"	633 24 7/8"	516,5 20 11/32"	513,5 20 7/32"	mm inch
RM 460	679 26 23/32"	676 26 19/32"	550,5 21 11/16"	547,5 21 9/16"	mm inch
RM 660	679 34 5/8"	676 34 1/2"	550,5 21 11/16"	547,5 21 9/16"	mm inch
RM 760 upper	286 11 11/32"	285 11 7/32"	550,5 21 11/16"	547,5 21 9/16"	mm inch
RM 760 lower	801 31 17/32"	798 31 13/32"	550,5 21 11/16"	547,5 21 9/16"	mm inch
RM 1300 upper	360 14 3/16"	357 14 1/16"	596,5 23 9/16"	595,5 23 7/16"	mm inch
RM 1300 lower	879 34 5/8"	876 34 1/2"	598,5 23 9/16"	595,5 23 7/16"	mm inch

