

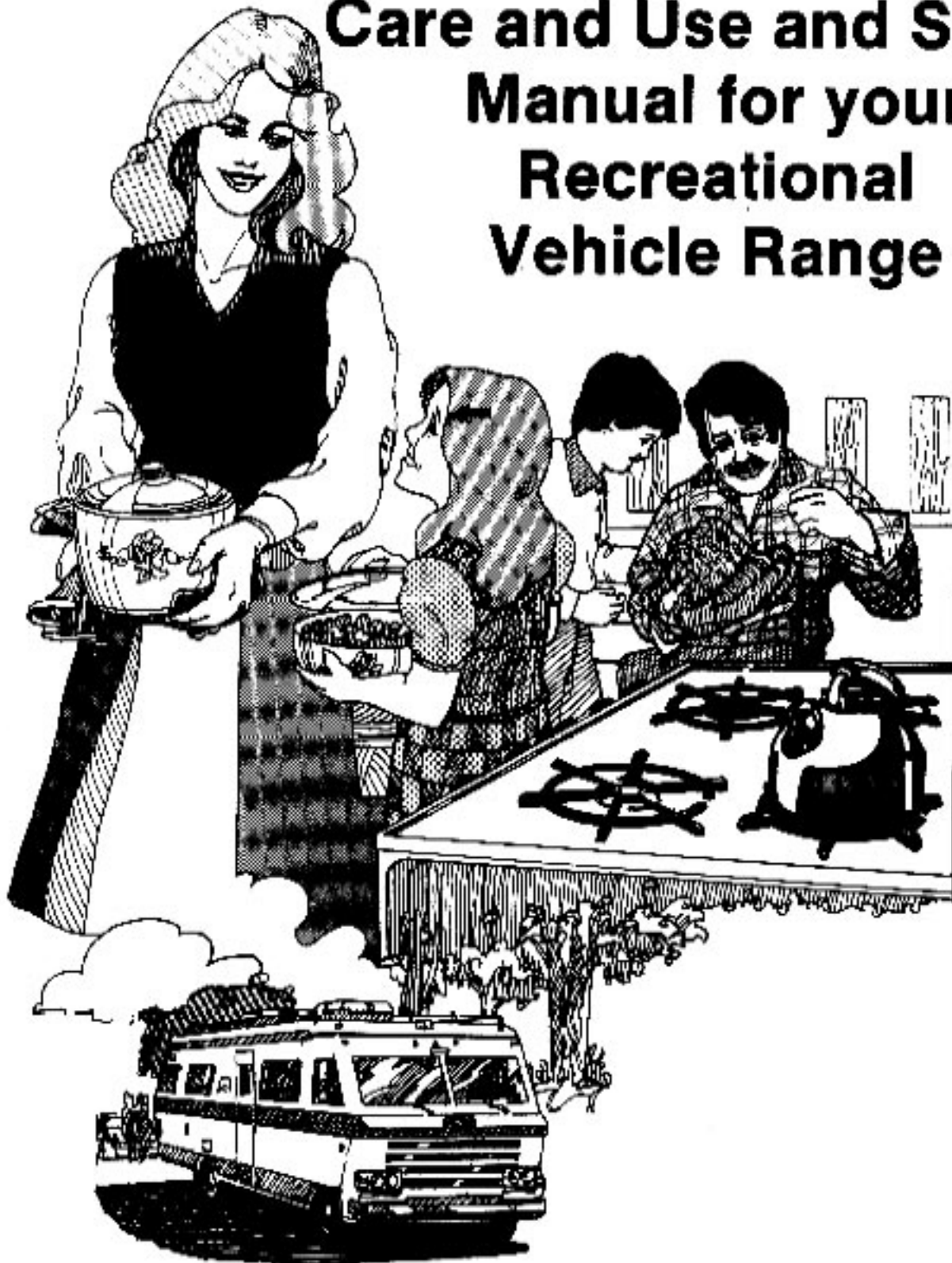

# MAGIC CHEF

## Care and Use and Safety Manual for your Recreational Vehicle Range





# MAGIC CHEF

Dear Magic Chef Customer:

We're so delighted that you have selected Magic Chef as your new range, and it is our personal pleasure to assure you that you have made a wise purchase. Generations of good cooks have learned to know and trust the performance and workmanship of their Magic Chef, and today we feel very strongly our responsibility to perpetuate the outstanding reputation of our products.

Although every part, feature and system has been manufactured with care and precision, you will not enjoy your range to the fullest extent possible unless you are prepared to use it properly. Although our Dealer or Builder will provide basic instruction about its use, we have painstakingly prepared this "Care and Use" manual so that you will have all necessary information right at your fingertips. We urge you to study it carefully before you attempt to use the range; the time required to do so will more than pay for itself in the extra success and pleasure you will derive from your range.

We want you to be a satisfied customer. No matter which model you have chosen, your Magic Chef range will give you years of good service. If you have any questions concerning its installation or performance, call your Magic Chef dealer. If you are not satisfied with the response you get and wish to contact Magic Chef directly, please address your inquiry or complaint to one of the locations listed below. In any correspondence please include the complete model and serial number of the appliance, the name and address of the dealer from whom you purchased the range, and the date of purchase.

We want you to know also that Magic Chef fully endorses the activity of the Major Appliance Consumer Action Panel, a non-partisan agency which exists solely for the purpose of resolving Consumer complaints when the dealer/manufacturer process does not perform satisfactorily. We do not believe that recourse to this agency will ever be necessary, but we do want you to know of its existence if the need should ever arise.

Thank You  
Magic Chef

**MAGIC CHEF, Inc**  
247 N. Vineland Ave.  
City of Industry, California 91744  
Service (213) 330-3204  
(714) 545-4789  
Parts (213) 961-3674

**MAGIC CHEF**  
28812 Phillips St.  
P.O. BOX 1145  
Elkhart, Indiana 46514  
(219) 264-9378

**Be sure to read safety manual before using range**

**NOTE:** The features covered in this manual are for various model ranges (For R.V. and Domestic use). Please disregard portion pertaining to features that are not on your particular range.

# Table of Contents

<b>SAFETY INSTRUCTIONS</b> .....	3-6	<b>PILOT ADJUSTMENTS</b> .....	8
<b>INSTALLATION CHECKS</b> .....	7	Top burner pilot .....	9
<b>CONTROLS AND ADJUSTMENTS</b> .....	8	Oven pilot .....	8
Control style 1, Propane gas only, no top		Air shutter adjustment .....	9
burner pilot .....	8	<b>HOW TO OPERATE YOUR RANGE</b>	
Lighting oven pilot .....	8	<b>CONTROLS</b> .....	9
Shut down instructions .....	8	Operating the oven control .....	9
Control style 2, Propane gas only, with		Broiling, Roasting Baking .....	9
integral top burner pilot .....	8	Using the top burners .....	9
Lighting pilots .....	8	Using the timer .....	9
Shut down instructions .....	8	<b>TO SAVE UNNECESSARY SERVICE</b>	
Control style 3, adjustable for natural or L.P.		<b>CALLS</b> .....	10
gas with integral top burner pilot .....	9	<b>CARE AND CLEANING</b> .....	11
Lighting pilot .....	9	<b>FLASHTUBE HOLD-DOWN CLIPS</b>	
Shut down instructions .....	9	<b>INSTRUCTIONS</b> .....	12
		Top burner grate removal .....	13
		<b>PROCEDURE FOR ORDERING PARTS</b> ...	13
		<b>RECREATIONAL VEHICLE APPLIANCE</b>	
		<b>&amp; PARTS DISTRIBUTORS</b> .....	14

## General Safety Precautions For Your Range

Unfortunately, statistics prove that the home is the most unsafe place you can be. This is even more sad because so many home accidents could have been prevented with just a little care and thought. Become familiar with your NEW range. It may have features with which you may not be familiar.

**READ THE CARE & USE & SAFETY MANUAL CAREFULLY** before **USING THE RANGE.** Then please follow these precautions for safe use of the range and train the whole family to observe them too.

**NOTE:** The following instructions are based on safety considerations and must be strictly followed in order to eliminate potential fire and shock hazard conditions.

## SOME WORDS ABOUT SAFETY

Accidents can be tragic -- especially because so many of them could be prevented with a little care and judgment on the part of the user of the appliance. There are some basic good practices we hope you will follow in using your range.

### FOR YOUR SAFETY

If you smell gas:

1. Open windows
2. Don't touch electrical switches
3. Extinguish any open flame
4. Immediately call your gas supplier.

### FOR YOUR SAFETY

Do not store or use gasoline or other flammable vapors and liquid in the vicinity of this or any other appliances.

## FLAME SELECTION

When turning on a top burner the user must stay near the range and make sure that the gas at the burner has been ignited. Then immediately adjust the burner flame to the correct size.

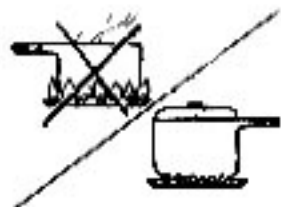

Selection of correct flame height is especially important to safety. Adjust the burner flame so that it is no larger than the bottom of the pan -- any higher flame is inefficient and can be a potential fire hazard.

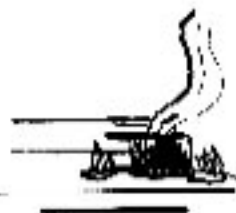

### Use of High Flame

When using a high flame, never leave the range unattended. Don't use a high flame setting for long periods of time. Hot fat is hazardous because it can catch fire.

Never leave surface units unattended at high heat settings.

Top surface burners are attended burners. While using them, periodic check is necessary for safe operation of top burners. Even at low settings do not leave the burners unattended for long periods of time.

Always check the position of the range top control knobs to make sure top burners/elements are off when you are finished with cooking.

## TEMPERATURE

In order to cook, you must have heat. As your range cooks, some parts of the range are going to get warm or even hot.



Do not leave children alone or unwatched near the range when it is in use or while the surfaces are still hot from use. Let burner grates and other surfaces cool before touching them.

## DO NOT USE RANGE AS HEATER



Never use the range as a kitchen heater. Prolonged use for heating without adequate ventilation can be dangerous. Also, ovens and top burners are not designed for heating use and can fail with such abuse.

## DO NOT USE RANGE AS STORAGE AREA

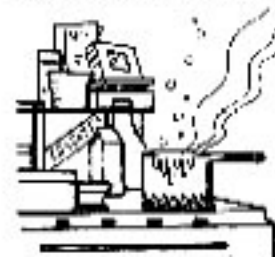

Do not permit the top burner section or the oven/broiler section of the range to become storage area for flammable or plastic items which may ignite or melt.

## CHILDREN



Children must be taught that the range and pans on it can be hot, that they should not play with range controls, and that the range should not be used as a stepstool to the cabinet above. Avoid storing items attractive to children in cabinets over or near the range.

## CLOTHING

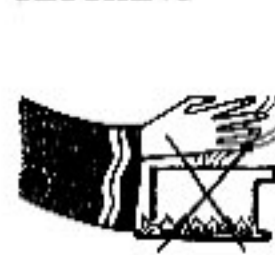

Clothing fires are a real kitchen hazard. Long, flowing sleeves have no place in a kitchen - they are too easily caught on pan handles, are easily ignited by range burners and are generally in the way. Highly flammable clothing especially some synthetic fabrics, robes and flannel pajamas, are also be most unsafe.



## POT HOLDERS



Buy good, sturdy pot holders and use them. Dish towels or other substitutes can cause bad burns when they are too thin or become entangled. Keep pot holders dry -- wet holders create steam and cause burns. Keep pot holders away from open flames when lifting or moving utensils.

## UTENSILS



### 1. Type

Avoid pans that are unstable and easily tipped. In choosing pans, look for easily-grasped handles that will stay cool. Pans that are too heavy to move easily when filled with food can also present a hazard. If pan handles twist and cannot be tightened, discard the pan.

Use utensils only as intended. This is particularly important for glass cookware. Some glass cookware should be used only in the oven; other pans are classified as flameware and may be used on top of the range.

### 2. Size



Select the right size utensil for the size of the burner, being sure the utensil is large enough to avoid boil-overs or spill-overs. This will both save cleaning and prevent accumulations of food, since heavy spattering or spill-overs left on a range can catch fire.

Never leave surface units unattended at high heat settings.



Pan size is especially important in deep fat frying. Always be certain the pan is large enough to allow for the volume of food to be added and for the fat to bubble up. A deep kettle is best for this. Foods high in water content, such as potatoes, bubble more than those low in water content. Never leave a deep fat frying operation unattended.

### 3. Handles



To minimize burns, ignition of flammable materials and spillage due to unintentional contact with the utensil, the handle of a utensil should be positioned so that it is turned inward, and does not extend over adjacent surface burners.



## 4. Hot Utensils

Let hot pans cool in a safe place -- out of reach of younger children. Never set hot pans on a combustible surface.

## PLASTICS



All plastics are vulnerable to heat, although some will withstand higher temperatures than others. Keep all plastics away from parts of the range which may become warm when the range is in use.

## GREASE



In the event of a grease fire, if possible first cover the pan to snuff out the fire. Do not use water to douse the flame. Use a fire extinguisher recommended for kitchen use, if available, or sprinkle heavily with baking soda.



Grease is flammable and should be handled carefully. Avoid letting grease deposits collect around the range or in vent fans. Don't leave cans of drippings around the range--refrigerate or dispose of them promptly. Let quantities of hot fat -- a pan of deep fat, for example -- cool before attempting to move or handle it.

## BROILER PAN

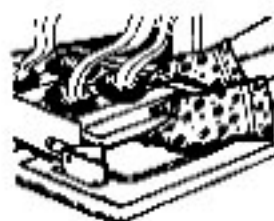

Always remove the broiler pan from the compartment as soon as you are finished broiling. It makes the pan much easier to wash and then there is no chance that the pan and drippings will be forgotten. Grease left in the pan can catch fire if the oven is used without removing the broiler pan. In using the broiler, remember too that if meat is too close to the flame the fat may ignite.

## OVEN USE

Do not heat an unopened glass or metal container of food in the oven. Buildup of pressure may cause the container to burst and result in serious personal harm and/or damage to the range.

Always let initial rush of heat and/or steam disperse from heated oven before placing or removing food. Do not allow excess spillovers to accumulate in the oven. Under some conditions, these may ignite and cause an oven fire. If fire occurs do not open the oven door. Immediately turn off the gas.



Always use a pot holder to pull the oven rack out, rather than reaching into the hot oven to add or remove food. Be sure to put racks and any removable oven rack supports back into the oven correctly after cleaning. They are designed to lock and not tilt when properly inserted.

Always check the position of oven control knob to make sure oven is off when you are finished cooking.

## EYE-LEVEL OVEN USE



Extreme caution is necessary when preparing heavy food items in an elevated oven, especially if considerable amounts of hot fat are involved; for example, a heavy roast with drippings.

## DO NOT USE OVEN DOOR AS A STEPPING STOOL



And please don't lean on a range. Loose fitting clothing might catch fire.

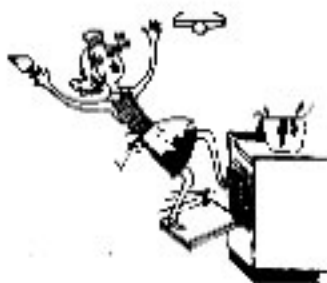

## ALUMINUM FOIL



Aluminum foil, used improperly, is a cause of many range fires—as well as baking problems. Use foil only as instructed—particularly in the broiler. Holes in the broiler pan or the air openings in the oven bottom should never be covered with foil.

## AEROSOL SPRAYS



Avoid their use near a range as most are highly flammable. Follow instructions on the container label.

## WHEN REPLACING OVEN LIGHT BULB, TAKE THESE PRECAUTIONS:



1. Wait until oven and bulb are cool.
2. Always handle bulb with dry (never a wet) cloth to protect hands.
3. If light bulb should break, before changing bulb disconnect power to the range by unplugging from outlet or by removing fuse or throwing circuit breaker.

## MAINTENANCE



Your range must be kept clean and free of accumulations of grease or spill-overs which may ignite.

## Do's and Dont's

- Never light matches in the vicinity if the odors of gas are noted.
- A window or other air vent should be open slightly while using the range. Gas flame consumes oxygen which has to be replaced to assure proper combustion.
- Do not tamper with the burner orifices or change their size.
- Do not leave the gas burning while traveling and especially while refueling your vehicle at a gasoline service station.
- Do not leave the top burners on without a utensil for any length of time. Overheating of the grate may cause the porcelain enamel to craze and chip.
- If your range is equipped with a top cover, do not leave it down with the top burners on. Turning on the burners with the covers down could cause incomplete combustion, or put the burner out. It is a hazard.
- Do not use broiler area to store utensils as the oven burner and pilot may become damaged, or knocked out of proper alignment.
- Use range only for cooking operations. It will work better and longer if treated with care and used as intended. Do not overload.
- Do not operate a range that is partially disassembled or when some part is missing or broken.
- Make sure top burner and oven control knobs and top pilot shut off valve (when provided) are all in "OFF" position while filling the propane/ butane tanks.

## INSTALLATION CHECKS TO BE MADE BY USER.

Do not repair or replace any part of the appliance unless it is specifically recommended in the literature you receive with the appliance. All servicing should be referred to a qualified technician. Insist that genuine Magic Chef replacement parts be used in the repair of your appliance. If for any reason the replacement component cannot be assembled mechanically and/or electrically, contact the Magic Chef service engineer. Do not rework the component and/or appliance wiring.

The installation, adjustment, and service of this range must be performed by a qualified gas installer and serviceman. This is necessary to insure proper operation and to avoid the possibility of damage to the appliance or injury to users. Before the installer leaves your premises, you may wish to question him on the following points:

1. **Clearances.** Be sure that the installer has observed all the instructions in the installation manual for minimum clearances to any combustible surface. Also, some types of wall tile may melt when exposed to excessive heat.
2. **Venting.** Never block the vents (air openings above and below the oven) of the range. They provide the air that is needed for the range to operate properly.
3. **Shutoff Valve.** Have the installer show you where the gas shutoff valve for the range is located so that you know how and where to turn off gas to the range.
4. **Type of gas.** There are two major types of gas—Natural and LP (bottled gas). Appliances designed for one gas cannot be used on the other without some adjustments. Be sure your range is correctly adjusted by a qualified serviceman for the type of gas on which it is to be used.
5. **Air Shutter Adjustment.** Burner air shutter opening to be checked and adjusted (if necessary) for proper burner lighting and flame characteristics. After the air shutter adjustment is made the air shutter screw must be in place and tightened.

### CAUTION: ALL RANGES REQUIRING ELECTRICAL SUPPLY MUST BE GROUNDED

When installing a new range or moving one to a new location in your home, have a qualified electrician verify that:

- Range circuits have adequately grounded, three-prong receptacles. Do not under any circumstances, cut or remove the third (ground) prong from the power cord plug.

- Be sure the installation complies with Local and National existing codes.

electrical power supply to the range must be disconnected before any component that is attached with a screw or fastener is removed.

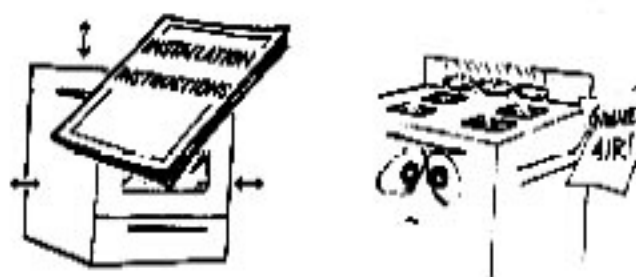

## SAFETY PRECAUTIONS TO BE OBSERVED WHEN USING YOUR RANGE

Learn the correct use of the range by reading the Care & Use Manual.

In case of future emergency, know where the main range gas shut-off valve and electric disconnect are located.

Use range only for cooking operations. It will work better and longer if treated with care and used as intended. Do not overload.

Keep your range clean and in good repair. Repairs should be done only by qualified personnel. Attempts to repair your range by others could result in damage or hazard.

Use preventative measures to avoid injury to children. Do not leave small children unattended near a range when the range is in use. As children mature enough to learn, instruct them in the safe, correct use of the range.

Remember, your range is a cooking device and some parts are intended to get hot. Train yourself to avoid the hot surfaces.

# Controls and Adjustments

## LIGHTING OVEN PILOT

**NOTE:** If range has not been operated for a long period of time a longer waiting period for ignition of the pilot may be necessary due to air in the gas line.

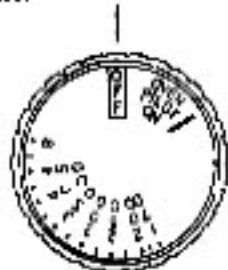

Oven Control knob  
in off position

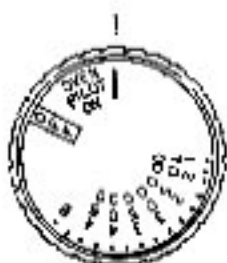

Oven Control knob  
in Oven Pilot On position

1. Be sure all valves are in the "OFF" position. The oven control knob should be in "OFF" position.
2. Turn on main gas supply to range.
3. Depress and turn control knob to the "OVEN PILOT ON" position. This will allow gas to oven pilot.
4. Open oven door and light oven pilot with a match. Small flame will be noted at the top of the pilot burner.

## SHUT DOWN INSTRUCTIONS

When oven cooking is finished, turn the oven control knob to the "OVEN PILOT ON" position, the oven standby pilot will remain lit.

When the Recreational Vehicle is not in use or while traveling, turn the oven control knob to "OFF" position and turn off main gas supply, this will turn off the oven pilot.

## LIGHTING TOP BURNER PILOT (WHEN PROVIDED)

**NOTE:** If range has not been operated for a long period of time a longer waiting period for ignition of the pilot may be necessary due to air in the gas

**NOTE:** Before turning on the main gas supply to the range be sure all top burner control knobs are in the "OFF" position.

1. Turn on main gas supply to range.
2. Lift main top panel and turn pilot shut off valve to on position.
3. Touch lighted match to pilot.

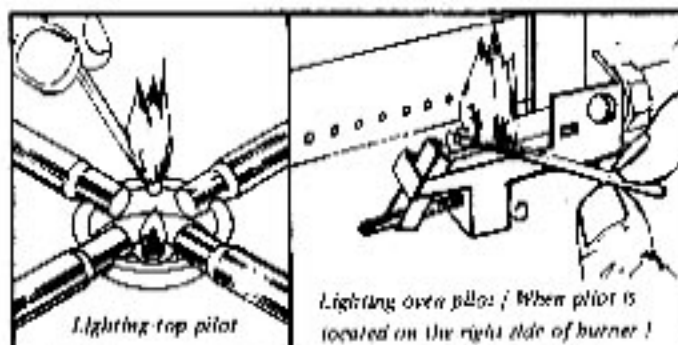

Lighting top pilot

Lighting oven pilot / When pilot is located on the right side of burner!

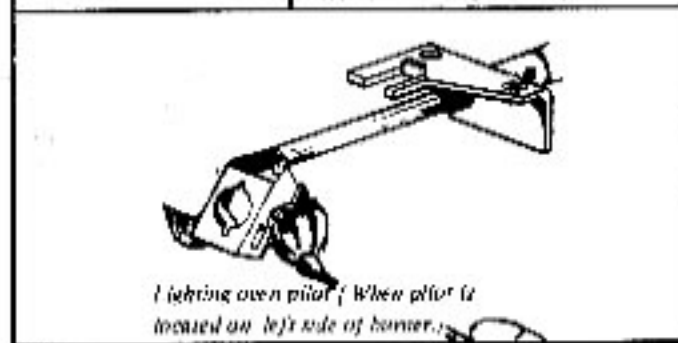

Lighting oven pilot / When pilot is located on left side of burner.

## SHUT DOWN INSTRUCTIONS

When top burner cooking is finished the control knob should be turned to "OFF" position, the top burner pilot will remain lit. When the Recreational Vehicle is not in use or while traveling, lift the main top and turn pilot shut off valve handle to "OFF" position and turn off main gas supply.

## Pilot Adjustments

### TOP BURNER PILOT

To adjust the top burner pilot, lift the main top and turn the pilot adjustment screw with a screwdriver. The top burner pilot flame should be about  $\frac{1}{8}$  of an inch above the lighter cup as shown in illustration.

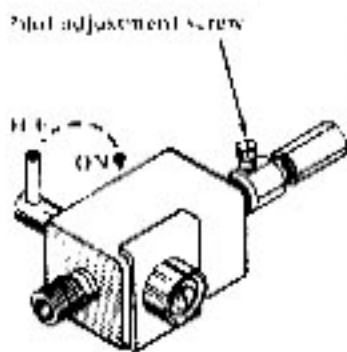

Pilot Shut Off Valve

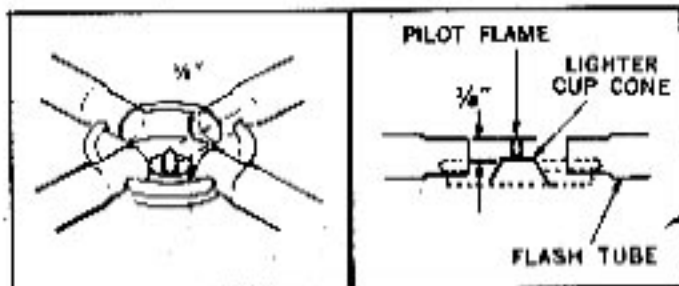



## AIR SHUTTER ADJUSTMENT

Air shutters when provided on top burners are to be adjusted so that each cone of the flame is separate and distinct and appears as illustrated. Air shutters set too far open will cause flame to lift away from burner head and will be difficult to light. If air shutters are closed too much the flame will look hazy and the distinct cone will be missing.



# How To Operate Your Range Controls

## OPERATING THE OVEN CONTROL

Depress and turn the oven control knob (counter-clockwise) to the desired temperature setting. There is a delay of about 45 seconds before the main burner ignites. This is normal and there is no gas escaping during this delay. It is also normal for the oven burner flame to cycle off and on, at all set temperatures except broil. This maintains a constant temperature in the oven.



## HELPFUL HINTS FOR BETTER COOKING

### BROILING

Broiling in your recreational vehicle range is very much like broiling in your kitchen range at home. Generally, the distance between the meat and the burner flame regulates degree of doneness and broiling time. Set oven control knob to broil "BR" position. Place food to be broiled on broiler grille and pan. Place pan in broiler (area directly below oven burner). You can count on your gas range broiler to provide smokeless, "closed-door" broiling.

## ROASTING

Season meat, if desired. Place meat fat side up on the rack in an uncovered pan. Turn oven control knob to the desired temperature. Most meats can be cooked at 300-325° F., but pork should be cooked at 350° F. Small poultry may be cooked at 375° F. for best browning. The only accurate way to tell internal doneness of meat (rare, medium, well done) is with a meat thermometer. Be sure thermometer is inserted into meat portion of the roast with tip not resting in fat or against bone. Add no water. Roast in oven to the doneness desired. No basting is necessary.

## BAKING

Make sure your oven is level, otherwise you may have uneven baking. After turning the oven control knob to the desired temperature, let the oven operate for about 10 minutes for preheating. When baking in one pan place it in the center of the oven. If a flat cookie sheet is used, allow two inches space between back, side, and front of oven. When glass or very dark metals are used for baking, reduce temperature setting recommended in the recipe by 25°.

## USING THE TOP BURNERS

### Models with top burner lighter pilot



This control has no pre-set position but the flame can be adjusted to any desired height between full on and off. To light the top burners, turn the control knob left (counter-clockwise) to full on position. From the full on position the flame may be lowered by turning knob back to the right (clockwise).

### Models without top burner pilot

Light match, turn control knob left (counter-clockwise) to the full on position, apply lighted match immediately to the burner. Adjust the flame height by turning the knob back toward the off position.

**CAUTION — DO NOT TURN CONTROL KNOB ON AND ALLOW GAS TO ESCAPE BEFORE LIGHTING MATCH.**

## USING THE TIMER

To set the 1-hour timer on models so equipped, turn the timer dial to the right (clockwise) to the desired number of minutes. At the end of the pre-set period a bell will sound.

**NOTE:** If the timer is to be set for less than 15 minutes, first turn the dial to 15 and then dial back (counterclockwise) to the lower setting.

# What To Do To Save Unnecessary Service Calls

Covered in this section are some of the most common complaints — their causes and corrections. By making a few simple checks you may save the bother and expense of a service call.

CONDITION	CORRECTION
1. ■ No gas to oven pilots	A. Check and make sure oven control knob is in "OVEN PILOT ON" position
2. ■ Oven slow heating up ■ Poor baking ■ Poor ignition of burners ■ Pilots won't stay lit ■ Popping sound from top burners ■ Carbon on pilot shield ■ Burner flame too low or too high	A. These conditions may be caused by a defective gas pressure regulator. Have the regulator tested by your gas dealer.
3. ■ Oven pilots will not light or stay lit	A. Be sure the pilots are adjusted correctly for type of thermostat being used. See pilot adjustment section. B. Check pilot tubings: may be kinked, clogged or leaking at fittings. C. Have gas pressure regulator tested. D. Be sure oven control knob is not in the "Pilot Off" position.
4. ■ Top burners won't light	A. Check and position top burners and flash tubing. B. Check pilot flame. C. Adjust air shutter, if equipped. See air shutter adjustment section. D. Clogged burner ports, clean with a toothpick.
5. ■ Gas smell	A. Check all connections with soapy water (never use a match or flame to check for leaks). This should be checked periodically in recreational vehicles as vibrations due to travel may loosen connections.
6. ■ Cake rises higher on one side	A. Pans set too close to side of oven. Allow two inches from side. B. Range not level.
7. ■ Cakes burn on bottom	A. Oven too full for proper circulation (see baking instructions). B. Using pan with dark bottom
8. ■ Oven will not operate	A. Check and make sure oven pilot is lit.

# Care and Cleaning

To keep your range looking bright and new, wipe all surfaces after use with a warm detergent solution and soft cloth. This should be done as soon as the range cools.

## PORCELAIN ENAMEL

Some foods contain acid which will dull the finish of the porcelain. Vinegar, lemon juices, tomatoes, and milk are a few. To avoid this happening, simply wipe-up spills immediately.

Remember, the surface is glass and must be given consideration in cleaning. Steel-wool pads, wire scourers, or gritty cleansers will scratch and wear down the surface. Any gentle kitchen cleansing powder or chemical grease remover will do a good job. Yet not harm the finish.

## CHROME

The best way to clean chrome surface on the range is to wipe them with a damp cloth and then dry thoroughly. Stubborn stains may be removed with chrome polish.

## GLASS

Wipe cooled glass with detergent and hot water. Rinse and polish with soft cloth.

## ALUMINUM

A light steel-wool soap pad will bring back luster and clean any stubborn stains or food spots. Avoid use of lye or caustic solution on aluminum parts.

## BROILER PAN AND INSERT

As soon as food has been transferred to serving plates, sprinkle pan and insert with soap powder or liquid detergent and cover with damp cloth or wet paper towels. Drippings will steam and loosen while your meal is being served.

**NOTE:** If oven bottom is removed for cleaning or servicing, be sure that oven bottom is locked in place when it is put back into the range. Oven bottom can be removed for cleaning by pushing in on both sides and lifting front to release from side supports.

**CAUTION:** If a commercial oven cleaner is used, protect aluminum gas tubing, thermostat sensing bulb and electrical components from the cleaners. (Masking tape is good for this.) Thoroughly rinse oven with a solution of 1 tablespoon vinegar to 1 cup of water.

If top burners are cleaned with any cleaning compound, care should be taken to see that all ports are opened up with a toothpick to insure proper operation. It is especially important that the lighter ports on the side of the burner head are kept clear.

## IMPORTANT: CHROME FINISHED MAIN TOPS

Due to certain atmospheric conditions and because of oxidation from the top pilot, the chrome top on your range may show signs of rust on the underneath side. This is especially true in areas of high humidity and salt air areas.

To help eliminate this condition, caution should be taken to make sure that the underneath side of the main top is kept dry in areas of high humidity where moisture accumulates. If you detect signs of rust, we have found it to be helpful to spray the underneath side with a coat of high heat tested rust-elimium or silicone paint.

**CAUTION:** Remove top from range and spray in well vented area.



# INSTRUCTIONS

## FLASHTUBE HOLD-DOWN CLIPS

### 3 AND 4 BURNER MODELS

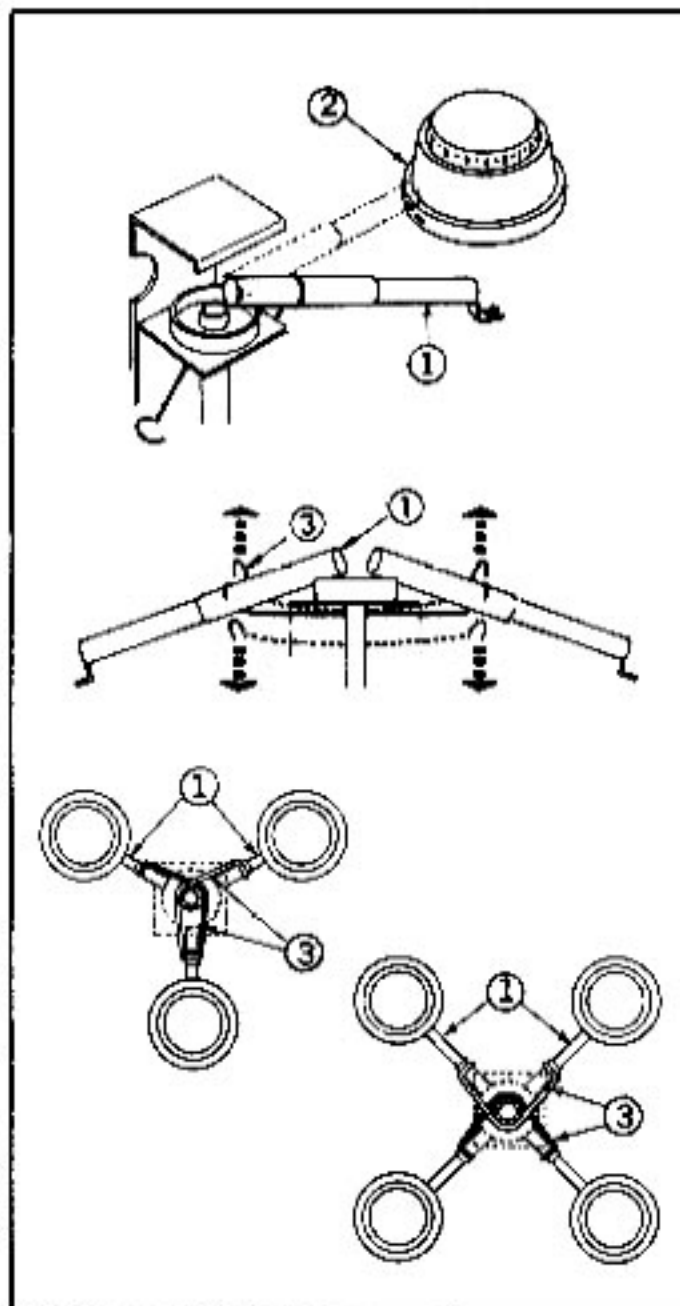

### 4 BURNER MODELS

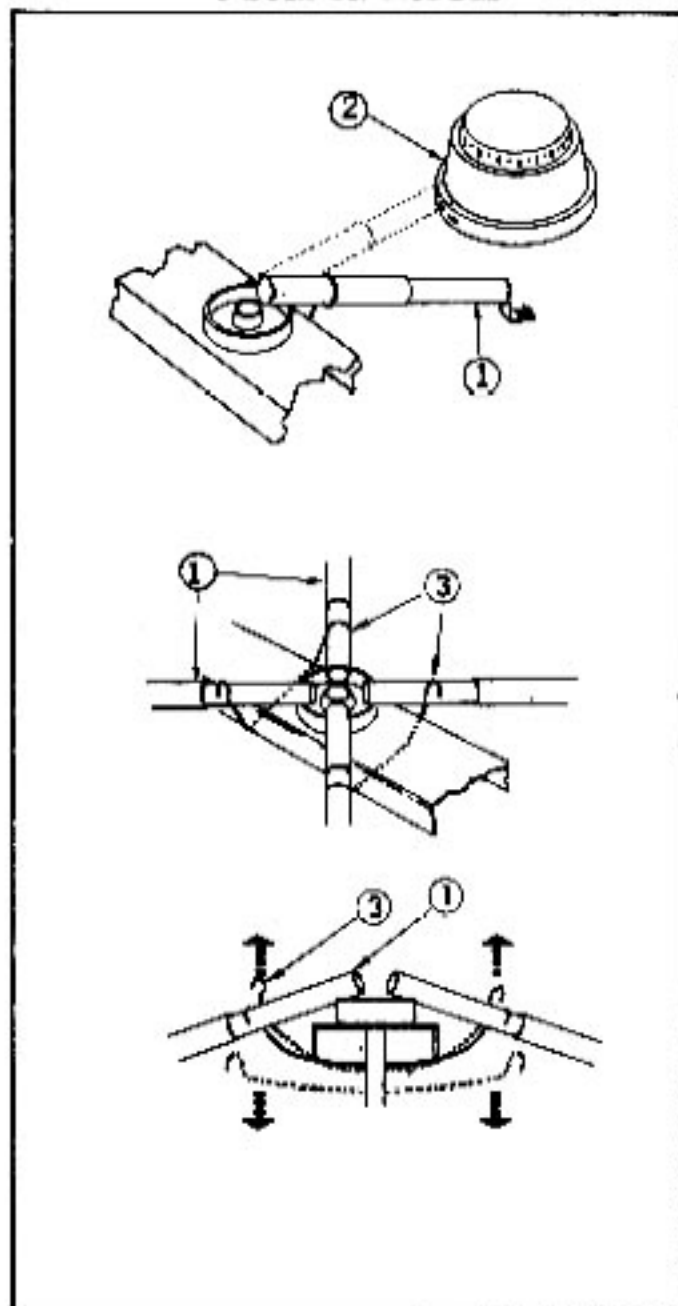

1. Remove flashtubes ③ from top burners ① as shown in illustration.
2. Lift clips ③ up carefully removing one end at a time from flashtube ③.
3. To install clips reverse procedure.



# Procedure For Ordering Parts

**Important:** The correct information will help us in expediting part orders and service to you.

## A. HOW TO ORDER PARTS

1. Please give the complete model and serial number of the range when ordering parts or requesting service.
2. This information includes all prefix and suffix letters and all code numbers.
3. This information is found on the number plates.

## B. LOCATION OF NUMBER PLATE

1. The number plate is located on the bottom side of the burner box, underneath the main top on the Eye-level drop in and Surface units. On the Built-in models the number plate is located on the front frame behind the oven door.
2. Example:

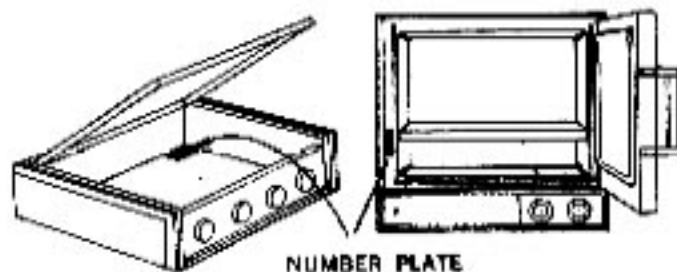

## C. IDENTIFICATION OF PARTS

1. All parts should be properly identified.
2. Use the parts breakdown description to properly identify part or parts. This information is shipped with every range.

### SERVICE DATA

Enter all the information below and retain for handy reference. Copy the following information from the Rating Plate.

MODEL NO. \_\_\_\_\_

SERIAL NO. \_\_\_\_\_

SPEC. CODE NO. \_\_\_\_\_

Be sure to mention all above numbers any time you call or write the company.

DEALER **PORTERVILLE TRAILER CENTER**  
1095 LINDA VISTA AVE.

DATE INSTALLED **PORTERVILLE, CA 93257**  
PHONE (209) 784-8088

SERVICE AGENCY \_\_\_\_\_

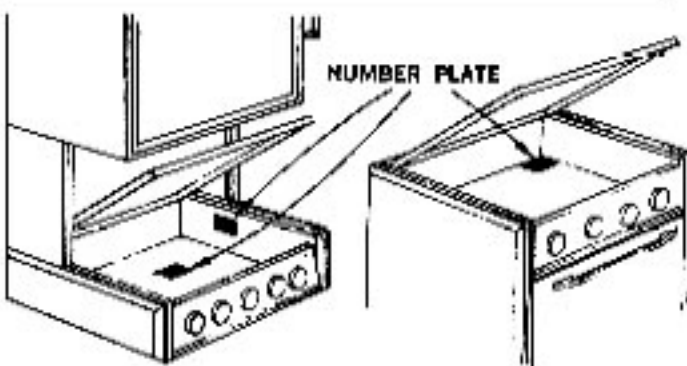

## TOP BURNER GRATE REMOVAL

### MODELS WITH SPLIT GRATES

First note that the ring of the grate has been cut to allow spring back tension (see illustration "A").

**CAUTION:** Care should be taken to see that all grates have been cooled before attempting to remove them.

To remove the top burner grates, grasp the cooled grate with either hand using your thumb and two or more fingers, place them inside the enclosed grate fingers (see illustration "B") then while lifting up, compress the grate ring together.

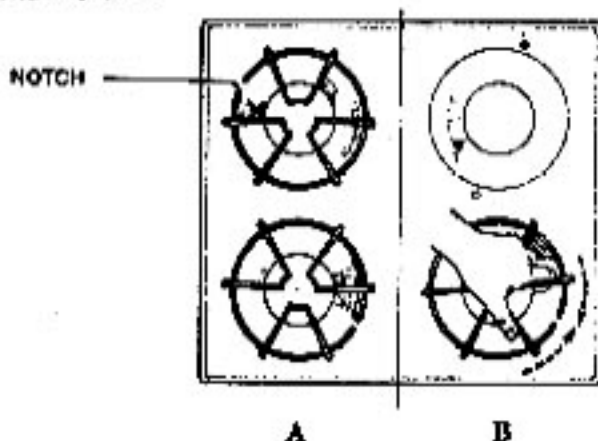



Our two factory Parts and Service Centers offer prompt and efficient service on MAGIC CHEF Recreation Vehicle Appliances

Ranges  
Refrigerators  
Microwave Ovens  
Trash Compactors

#### MAGIC CHEF FACTORY PARTS & SERVICE

Magic Chef,  
28812 Phillips Street  
Elkhart, IN. 46415  
219/264-2128 -----Parts  
219/264-9578 -----Service

Magic Chef, Inc.  
2730 20th Street N.E.  
Cleveland, Tennessee 37311  
615/472-3371

Magic Chef Regional Parts & Service  
247 N. Vineland Avenue  
City of Industry, CA. 91744  
213/330-3204 -----Service  
213/961-3674 -----Parts

#### RECREATIONAL VEHICLE APPLIANCE & PARTS DISTRIBUTORS

Atlantic Mobile Home Supply  
4828 Highpoint Road  
Greensboro, N.C. 27407  
919/299-4691

Northwest Trailer Parts, Inc.  
6750 N.E. Columbia Blvd.  
Portland, OR. 97218  
503/288-7431

Stag Trailer Supply, Inc.  
5485 Tulare Drive S. W.  
Atlanta, GA. 30336  
404/691-9191

Tweedy's Mobile Home Supply, Inc.  
Route 4, Box 190-C  
North Little Rock, AR. 72117  
501/835-1464

Bell Industries  
1801 E. Highway  
St. Paul, MN. 55109  
612/484-0291

Richey's Appliances  
2931 W. 25th Ave.  
Denver, CO. 80211  
303/455-3681

Stags Trailer Supply- Maryland  
301/796-8055

Guy Isley's Wholesale Dist.  
2225 W. Main Street  
Mesa, AZ. 85201  
602/ 834-1234

Rogers Distributing Company  
281 N. Sherman Way.  
Corona CA. 91720  
714/371-4884

Sunwest Distributors  
3800 West 2100 South  
Salt Lake City, UT. 84120  
801/973-4900

Leisure Time Distributors  
1901 Wellington Road  
Manchester, N.H. 03104  
6036 603/623-7056

G.E. Sisk, Inc.  
324 - 13th St. S.W.  
Largo, FL. 33540  
813/584-8195

Trailer Parts Supply, Inc.  
421 E. 21 st North  
Wichita, KS. 67214  
316/262-3701

#### CANADIAN DISTRIBUTORS

Fennell's Trailer Supply 6459 Patricia Bay Hwy Victoria, B.C. Canada  
V84 1T8 604/652-3941

B&B Trailer Supplies, LTD. 710 LaPine Ave. Dorval, Quebec, Canada H9P 1G2  
514/636-6200 London, Ontario Canada 519/881-9402  
Moncton, New Brunswick, Canada 508/382-5986

# MAGIC CHEF SERVICE PARTS LIST

RANGE SERIES BT22K-4

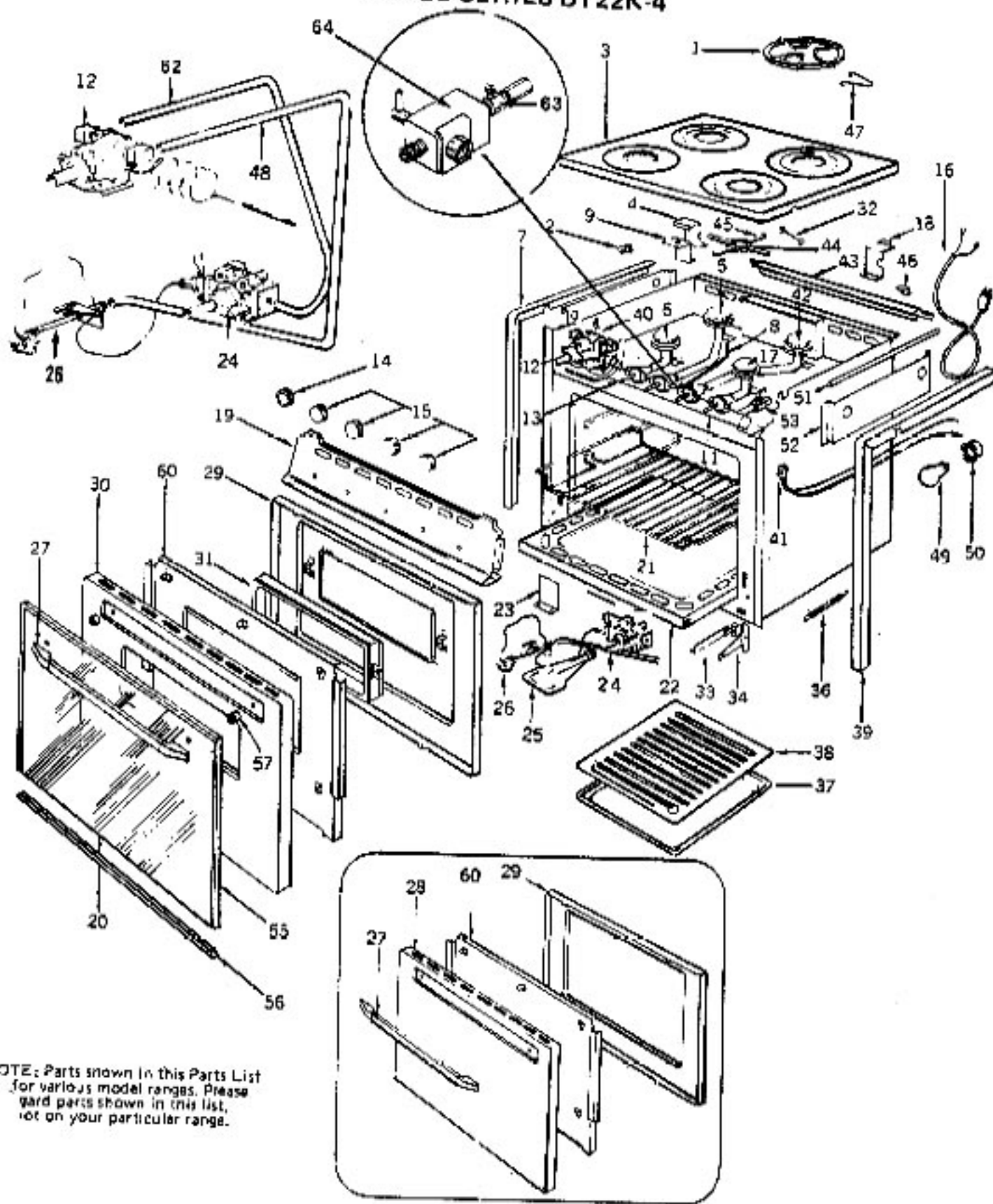

NOTE: Parts shown in this Parts List for various model ranges. Please guard parts shown in this list, not on your particular range.

# RANGE SERIES BT22K-4T

KEY NO.	DESCRIPTION
1	Top grates
2	Tee nut (4)
3	Main Top
4	Top pilot shield
5	Left rear burner
6	Left front burner
7	Left side trim
8	Top pilot tube
9	Top pilot support
*10	Light switch shield
11	Manifold pipe
12	Thermostat
13	Top burner valve
14	Thermostat dial
15	Top burner knobs
16	Supply cord
17	Right front burner
18	Junction box
19	Manifold panel
20	Outside glass
21	Oven rack
22	Oven bottom
23	Broiler pan stop
24	Oven burner valve
25	Oven burner
—	Oven burner a.r. shutter
26	Oven pilot
27	Oven door handle
28	Oven door panel
29	Oven door liner
30	Oven door panel (with window)
31	Window assembly
32	Flashtube hold down clip
33	Door hinge assembly R.H.
—	Door hinge assembly L.H.

KEY NO.	DESCRIPTION
34	Spring hinge arm
35	Door spring
**37	Broiler pan
**38	Broiler pan insert
39	Side trim—Right
40	Main top hold down clip
41	Oven light switch
42	Right rear burner
43	Flue deflector
44	Lighter cup assembly
45	Flash tube
46	Main top rear spring
47	Grate clip
48	Pilot tubing
49	Oven light bulb
50	Oven light receptacle
51	Oven light harness tubing
52	Heat shield
53	Shut off valve
54	Gas supply tubing
55	Upper glass frame
56	Lower glass frame
57	Nylon spacer
*58	Vertical door seal
*58	Horizontal door seal
*59	Vertical Door seal strap
*59	Vertical door seal strap
60	Insulation retainer
*61	Thermostat inlet fitting
62	Gas supply tubing
63	Pilot Filter
64	Pilot shut-off valve

\*Not shown in drawing

\*\* Not provided in models with spec code 35

## MAGIC CHEF FACTORY PARTS & SERVICE

Magic Chef,  
28812 Phillips Street  
Elkhart, IN. 46415  
219/264-2128 -----Parts  
219/264-9578 -----Service

Magic Chef, Inc.  
2730 20th Street N.E.  
Cleveland, Tennessee 37311  
615/472-3371

Magic Chef Regional Parts & Service  
247 N. Vineland Avenue  
City of Industry, CA. 91744  
213/330-3204 -----Service  
213/961-3674 -----Parts

## RECREATIONAL VEHICLE APPLIANCE & PARTS DISTRIBUTORS

Atlantic Mobile Home Supply  
4828 Highpoint Road  
Greensboro, N.C. 27407  
919/299-4691

Northwest Trailer Parts, Inc.  
8750 N.E. Columbia Blvd.  
Portland, OR. 97218  
503/288-7431

Stag Trailer Supply, Inc.  
5456 Tulare Drive S. W.  
Atlanta, GA. 30326  
404/891-9191

Tweedy's Mobile Home Supply, Inc.  
Route 4, Box 100-C  
North Little Rock, AR. 72117  
501/835-1464

Bell Industries  
1301 E. Highway  
St. Paul, MN. 55108  
612/484-0291

Richey's Appliance  
2931 W. 25th Ave.  
Denver, CO. 80211  
303/455-3881

Stags Trailer Supply- Maryland  
301/796-8055

Sunwest Distributors  
3800 West 2100 South  
Salt Lake City, UT. 84120  
801/973-4900

Guy Iley's Wholesale Dist.  
2225 W. Main Street  
Mesa, AZ. 85201  
602/ 834-1234

Rogers Distributing Company,  
231 N. Sherman Way.  
Corona CA. 91720  
714/371-8664

Leisure Time Distributors  
1901 Wellington Road  
Manchester, N.H. 03104  
603/ 603/523-7055

G.E. Siek, Inc.  
324 - 13th St S.W.  
Largo, FL. 33540  
813/584-8185

Trailer Parts Supply, Inc.  
421 E. 21st North  
Wichita, KS. 67214  
316/262-3701

## CANADIAN DISTRIBUTORS

Fennell's Trailer Supply 6458 Patricia Bay Hwy Victoria, B.C. Canada  
V84 1T8 604/652-3941

B&B Trailer Supplies, LTD. 710 LaPine Ave. Dorval, Quebec, Canada H9P 1G2  
514/636-6200 London, Ontario Canada 519/681-9402





# MAGIC CHEF®

Dear Consumer:

Your recreational vehicle range was carefully inspected and tested before shipping. To assure you further we provide you with the Limited Consumer Protection Warranty set forth below.

## LIMITED CONSUMER PROTECTION WARRANTY MAGIC CHEF RECREATIONAL VEHICLE RANGE

This warranty gives you specific legal rights, and you may also have other rights which vary from state to state.

Subject to the limitations set forth, we warrant your recreational vehicle range under normal use and repair against defects in workmanship or material for a period of one year from date of installation.

Under this warranty we will replace any defective part at no cost or expense to you except for the costs of delivery and labor involved in the removal of the defective part and the installation of the replacement. The replacement part assumes the unused portion of this warranty.

This warranty applies only within the contiguous 48 states of the continental United States.

### LIMITATIONS

1. Porcelain Enamel and Decorative finishes. Porcelain enamel is actually glass fused on steel and will chip or craze if not properly cared for. This warranty does not apply to porcelain enamel or other finishes or to scratches in or discoloration of decorative finishes.

2. Consumable Items. This warranty does not apply to light bulbs or fluorescent tubes which must be periodically replaced in the course of routine maintenance.

3. External Factors. This warranty does not apply to damage

to the product caused by misuse, failure to maintain the unit properly, accident or act of God.

4. EXCLUSIVE WARRANTY. This limited written warranty is the only warranty made by Magic Chef. This limited warranty is in lieu of any other warranties or liabilities on the part of Magic Chef except for implied warranties which are limited as to duration. Magic Chef does not authorize any person to provide any other warranty or to assume any further obligation in connection with the sale of this Magic Chef range.

5. LIMITATION ON IMPLIED WARRANTIES. Implied warranties of merchantability or, to the extent applicable, fitness for a particular purpose are limited to one year, the same duration as the basic limited written warranty provided hereby. Some states do not allow limitations on how long an implied warranty lasts, so the above limitations may not apply to you.

6. CONSEQUENTIAL DAMAGES. Magic Chef shall not be responsible for any consequential damages caused by defect in the range. Some states do not allow the exclusion or limitation of incidental or consequential damages, so the above limitation or exclusion may not apply to you.

If the range fails to operate properly, we ask you to do the following:

1. Whenever requesting service, please be sure to give the model and serial numbers which are found on the rating plate of your range.

2. Contact your recreational vehicle dealer or contact a Magic Chef Service Agency in your area or contact us directly to obtain the name, telephone number and address of your nearest Magic Chef Service Agency.

West of the Rockies contact: Service Department,

MAGIC CHEF, Inc  
247 N. Vineland Ave.  
City of Industry, California 91744

East of the Rockies contact: Service Department,

MAGIC CHEF  
28812 Phillips St., Elkhart, Indiana 46514

3. If our Service Agency does not repair your range to operate properly within the warranty period, please write us directly giving us all pertinent information so that we can assist you.

Sincerely,  
MAGIC CHEF